

ZnO Nano Particles (NPs) Properties Prepared by Liquid Phase Laser Ablation (LPLA)

Khaleel I. Hassoon, Sabah H. Sabeeh and Mustafa A. Khalaf
Department of Applied Science, University of Technology, Baghdad–Iraq.
E-mail: mustafa14aks@gmail.com.

Abstract

In this work ZnO NPs have been prepared by liquid phase laser ablation technique from Zn target immersed in ethanol solution. The effect of laser energy and the number of laser pulses of LPLA technique which includes the optical, morphological and structural measurement were investigated. The XRD measurements confirm the presence of ZnO nano size and particle size of average of 41 nm; this has good agreement with TEM measurement. The optical measurements show the increases in the number of the laser pulses as well as increase the laser energy lead to increase the energy band gap, however the absorptions peaks appears to be at the average of 298 nm which yield an energy band gap of 3.5 eV. [DOI: [10.22401/JNUS.20.1.10](https://doi.org/10.22401/JNUS.20.1.10)]

Keyword: Liquid Phase Laser Ablation, ZnO, Nanoparticles, Energy Band Gab.

1. Introduction

Nano sized particles of semiconductor materials have gained much more interest in recent years due to their desirable properties and applications in different areas such as catalysts, sensors, photoelectron devices, highly functional and effective devices. The bulk properties of a wide direct band gap (3.37 eV at room temperature) and high exciton binding energy (60 meV) are appealing for a new generation ultraviolet (UV) optoelectronics, including light-emitting diodes, diode lasers and field emission displays [1]. It has been used considerably for its catalytic, electrical, optoelectronic, and photochemical properties [2]. Also ZnO has been commonly used in its polycrystalline form over hundred years in a wide range of applications, and optical properties like N-type conductivity, absorption spectra and electroluminescence decay parameter [3]. Because of its interesting properties, zinc oxide has been the subject of study by many researchers. This has led to the development of a great variety of techniques for synthesizing the compound such as laser ablation, electrochemical depositions, chemical vapor deposition, thermal decomposition and composition method [4], and Controlled precipitation. Also ZnO powder has been prepared by sol-gel method [5]. Recently, ZnO NPs were prepared by ultrasound, microwave-assisted composition method.

2. Experimental Work

The experimental setup used to prepare ZnO NPs colloidal by the laser ablation technique in liquid medium is shown in Fig.(1). The setup of the system above provides the ability to produce NPs by the ablation process at different number of energies and pulses at fixed solvent which is ethanol. The colloidal suspensions obtained were characterized.

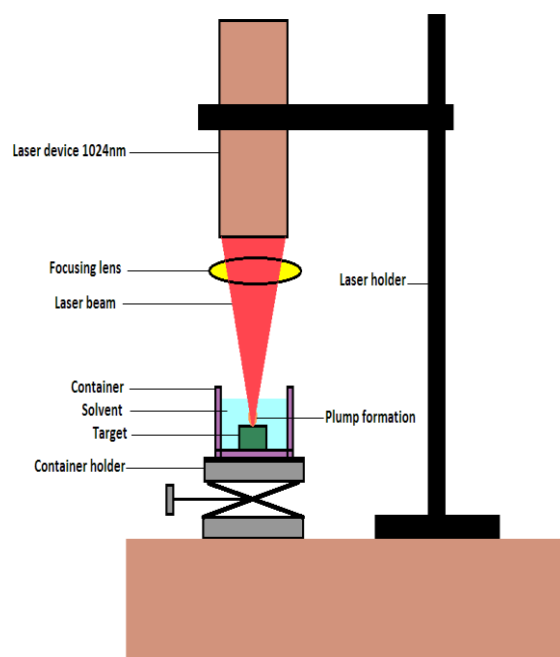

Fig.(1): Experimental setup for liquid phase laser ablation system.

The pulse laser ablation in liquid media system containing the following parts:

Laser beam

A pulsed Nd:YAG laser system type (HUAFEI) of solid state active medium crystal that operates in the Q-switched mode. This laser deliver high energy very short pulses at wavelength in the infrared region at 1064 nm. The laser beam diameter is 4.3 mm focused by a lens of 120 mm focal length to achieve high laser fluence focused on the target to achieve laser ablation process. The energy delivered to the target is ranged between 500 and 900 mJ obtained after calibration by joule meter as well as the number of pulses have been varied in this work between 60 and 140 pulse, the output pulse duration is 10 ns, repetition rate (1Hz) .

Container

Plastic vessel was used in the process of laser ablation as a container. The zinc target placed on the bottom of plastic container and filled with 3 ml of high purity ethanol as a solvent. The solution depth was around 2-3 mm during laser ablation.

Solvent

In this work, there is one solvent was used as a suspension media which is (organic solution) ethanol (Scharlau Co., $\text{CH}_3\text{CH}_2\text{OH}$, 99.9% purity).

Target

The material used as target for ablation process was Zinc (purity 99.8% made in china). The target shape was circular with dimension of $1 \times 1 \text{ cm}^2$ and height of 1mm. The surface was cleaned by wash it with deionize water then cleaned by high purity ethanol before each ablation process to remove contamination such as dust and oxide layer that was created on the target surface.

ZnO NPs Formation

The formation of zinc oxide take a place when the zinc target is irradiated by a Q-switched Nd:YAG laser beam that operating at (1064 nm wavelength and 10 ns pulse duration). The target was placed under the laser device immersed in ethanol media with

3 ml volume in a container of 5cm diameter and 5cm in height at room temperature. The container that contains the target placed on the cell holder. This process is produced by a mechanism called plump formation which stimulates agglomeration for the NPs that affect the deposition method later on in the next technique. It also notice when the NPs being processed the color of the suspensions change visually and indicate of NPs productions.

Silicon Wafer Preparation

The silicon wafer is p-type (111) since the ZnO NPs are n-type, with resistivity about $1.5\text{-}4 \ \Omega\cdot\text{cm}$ and $(500 \pm 15 \ \mu\text{m})$ thickness. It was cut to $1 \times 1 \text{ cm}^2$ area which has been used us a substrate. Then it washed with ethanol to remove contamination such as dust after that the Si wafer immersed in (5%) hydrochloric (HCl) acid to remove the negative oxide layer then washed again with ethanol and dried by a special paper.

3. Results and Discussion

3.1 XRD Measurements

The measurements via X-ray diffraction spectra showed that the zinc (Zn) target which in this case a pellet match with the JCPDS standard, any way Fig.(2) shows an agreement between XRD spectra of the target and JCPDS standard card (JCPDS PDF #00-004- 0831) for Zn target which has a light gray metallic color.

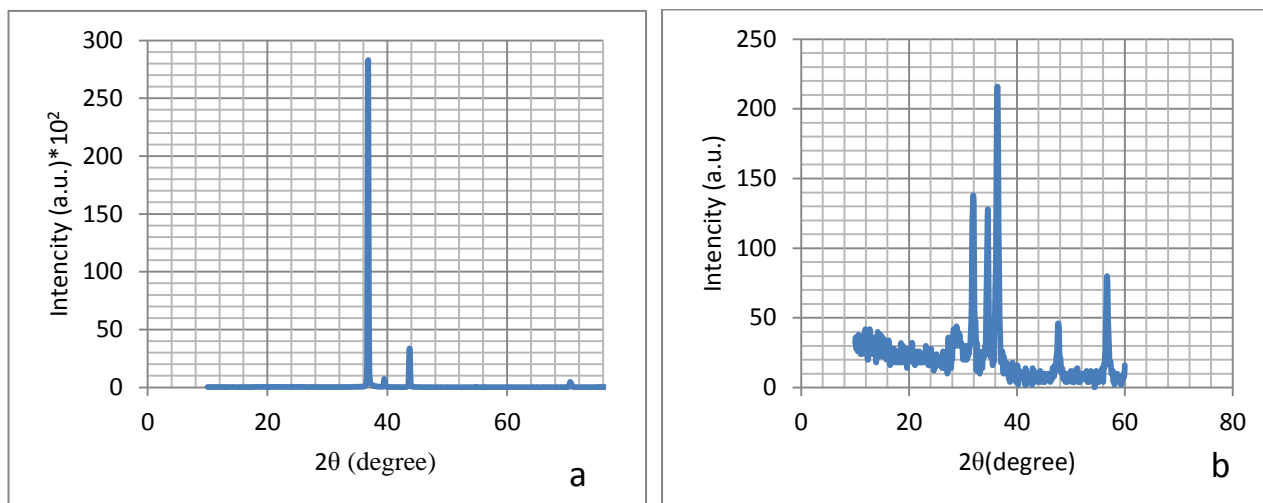

Fig.(2): XRD spectra of (a) Zn target as a pellet and (b) ZnO target as a nano particles thin film prepared by electrophoretic deposition (EPD).

Fig.(2b) shows the X-ray diffraction patterns of the ZnO nano particles suspensions prepared by laser ablation of zinc target immersed in ethanol of 3 ml in volume with 2 mm pellet depth from the surface of ethanol at laser energy of 700 mJ and 100 pulse 1 Hz repetition rate laser beam (100 sec method pried time). This NPs were carried out on a dry thin film that obtained by EPD technique of voltage applied of 350v with distance between the poles of 6mm and substrate area of $1 \times 1 \text{ cm}^2$ and time of deposition is 5sec also current flow has been recorded with 6mA deposited on a (111) p-type high resistivity silicon wafer, also this figure showed the agreement between XRD spectra of the thin film and JCPDS standard card for ZnO (JCPDS 036-1451) which has hexagonal arrangement [6].

Fig.(2a) and Table (1) shows the XRD patterns of the Zn bulk target of four narrow peaks (002), (100), (101) and (110) at angles of 36.9,39.5,43.7 and 70.7 degree respectively which refer to zinc metal now after processing zinc metal by LPLA technique and form a film by EPD technique for another XRD measurement as shown in Fig.(2b) a new five broader XRD pattern appears with orientation of (100),(002),(101),(102) and (110) at angles 31.8, 34.6, 36.4, 47.7 and 56.7 degree respectively refer to ZnO material, a successful transformation from zinc material to zinc oxide material during laser ablation process has been obtained. The sharpness of the diffraction peaks indicates high

crystallinity of the as-grown samples for the zinc oxide figure. All peaks are accounted for either from ZnO or pure Zn metal. No characteristic peak of other chemical compounds was obtained.

Table (1)

The obtained result of the XRD FWHM, (D_g) grain size and (d) inter plane distance for Zn target.

2θ (deg.)	Plane (hkl)	FWHM (deg.)	Grain size (D_g) (nm)	d-spacing (nm)
31.8	100	0.2	41.44797	0.28217
34.6	002	0.2	41.751	0.259951
36.4	101	0.2	41.96147	0.2475
47.7	102	0.2	43.58398	0.191181
56.7	110	0.2	45.29472	0.162792

3.2 Yield Measurements

This measurements has been used only in LPLA part to measure the amount of the ablated material after treated by pulse laser process, the type of material used is zink. The zink material has been used in a form of a five different pellet each one of them processed by LPLA separately, the way this measurement works is by measuring the weight of each five pellet using four digit sensitive balance before and after the LPLA process then a simple mathematical calculation by minus the weight of the pellet before the ablation from the same pellet after the ablation process to give us the amount of the material being removed from the surface of the pellet to form a shape of

nano particles by a complicated process. These pellets placed in the bottom of a vessel or container contain the suspension which the nano particles dispersed in. Each pellet processed by a different laser parameter in this case the laser pulse energy is varied between 500mJ and 900mJ and also the laser pulses are varied between 60 and 140 pulse to study the yield property for LPLA which helps us to calculate the density of nano particles dispersed in the suspension after measuring the size of these colloidal using other different measurements.

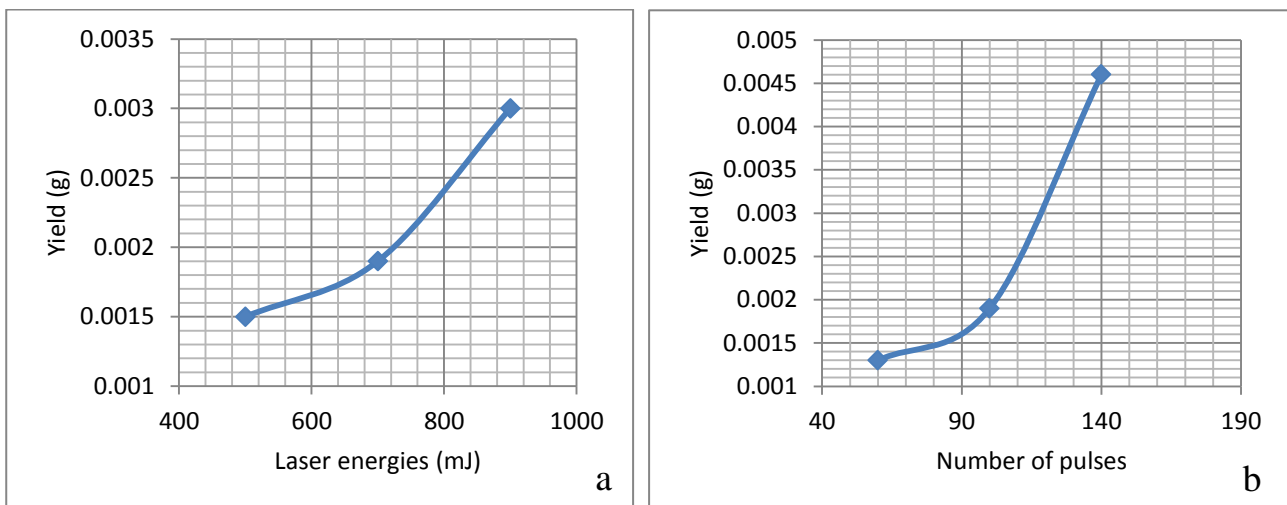

Fig.(3): Yield measurements of ZnO nano particles suspensions in ethanol solvent at two parameters (a) laser energies and (b) laser pulses.

Fig.(3a) shows the NPs yield versus variation of laser energy. As expected the energy increasing of the laser beam pulse increase the amount of yield due to higher amount of energy being absorbed by the target surface of zinc material. While Fig.(3b) shows the yield of NPs versus variation of laser pulses, from the figure increasing the number of pulses cause to increase the amount of yield however unlike the energy parameter the function is nonlinear the reason of that is may attributed to an increase of the NPs density in suspension that enhance the plump formation.

3.3 UV-Vis measurements

UV-Vis measurements of optical absorbance spectra for colloidal suspension which contains ZnO nano particles prepared by laser ablation process at different conditions has been studied as the following:

3.3.1 Effect of Laser Energy

Fig.(4) shows the UV-Vis absorption spectrum of colloidal ZnO NPs which has been ablated from Zn target formed as a pellet immersed in ethanol liquid of 3ml, the distance between the target surface and the ethanol surface was 2 mm. This process achieved by focusing the Nd:YAG pulsed laser beam of 1064 nm with different parameters of laser energies which were changed from 500 mJ to 900 mJ with 1Hz repetition rate and 10 ns pulse duration while the number of laser pulses were kept constant at 100 pulse. The peaks of the optical absorption for all the samples prepared with changing of laser energy have strong shifting in the UV range. This figure shows an increase in the absorbance spectra intensity with increasing the laser energy. One explain describe the increasing in the intensity using this particular device which is increase in the concentration of the ZnO nano particles formed in solution

during the ablation process [7]. The increasing in the laser energy cause more evaporated material affected by delivering higher laser energy which lead to increase the amount of masses produced side the suspension and increases the concentration of the NPs. It is worth to mention that this process is done in organic environment of ethanol suspension and the point is changing the liquid may change the results.

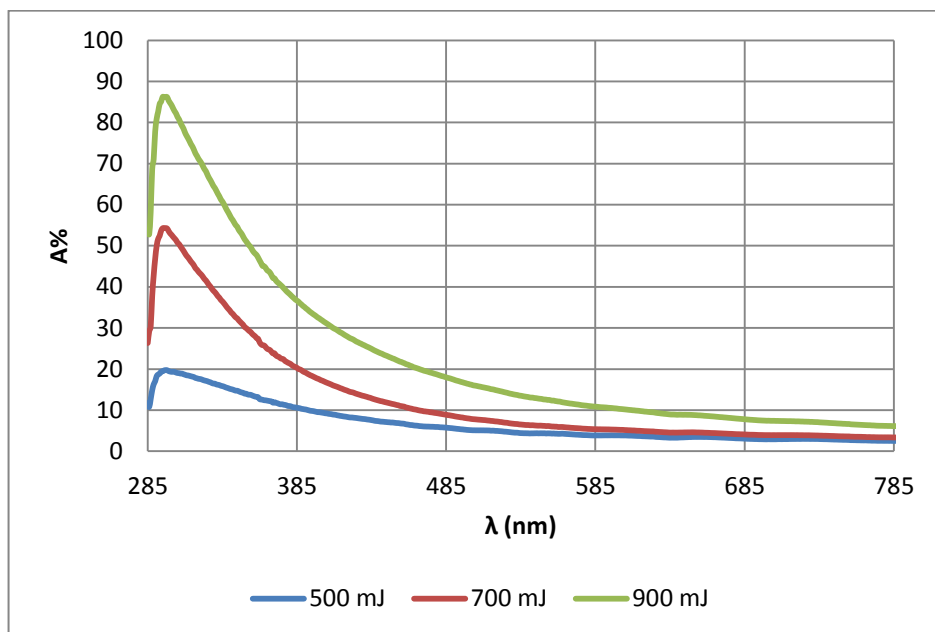

Fig.(4): Shows the absorption of the UV-Vis measurement for different laser energies.

3.3.2 Effect of Laser Pulses

Also the laser pulses parameter shows an important effect on the formation of the ZnO nano particles which is the number of laser pulses. Fig.(5) shows the UV-Vis absorption spectrum at room temperature of colloidal ZnO nano particles which has been ablated from Zn target formed as a pellet immersed in ethanol liquid of 3ml same of first parameter, also the distance between the target surface and the ethanol surface was 2mm. This process achieved by focusing the Nd:YAG pulsed laser beam of 1064 nm with lens of focal length of 8.25 cm with different parameters of laser pulses which were changed from 60 pulse to 140 pulses with 1Hz repetition rate and 10 ns pulse duration while the laser beam energy were kept constant at 700 mJ. As well as the parameter of laser energy the optical absorption spectra in this parameter for all the samples prepared with varying the laser pulses placed in the UV range.

The UV-Vis measurements spectra were similar to the spectra obtained in Fig.(4). The increasing in the number of laser pulses cause to an increase in absorbance peak intensity with applying different number of laser pulses as shown in Fig.(5). As predicted the increase in the number of laser pulses lead to increase the quantity of NPs in the suspension, these nano particles will intercept the laser beam incident on the target when they gathered near the surface of the ethanol after many laser pulses. This will create more complication during the laser energy absorption by the nano particles size reduction [8].

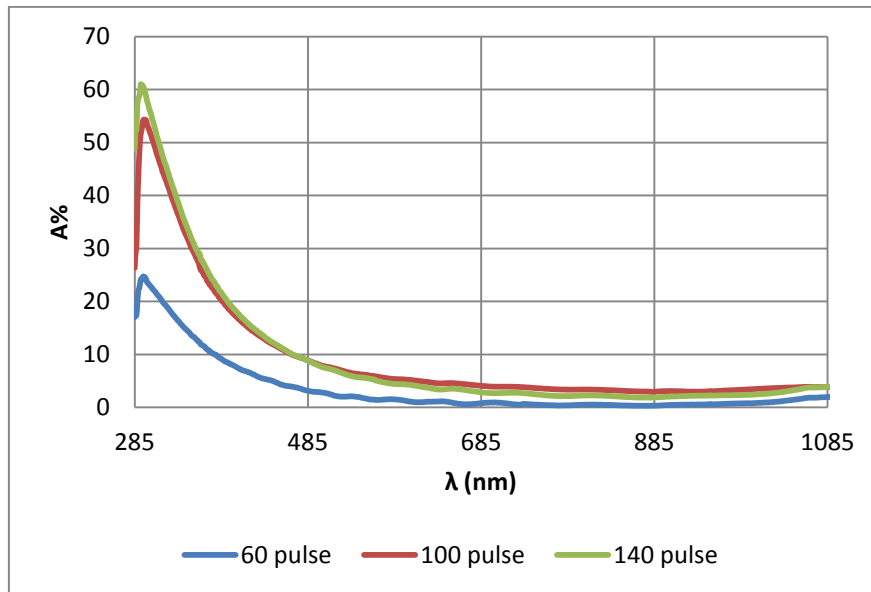

Fig.(5): Shows the absorption of the UV-Vis measurement for different number of laser pulses.

3.3.3 Optical Energy Gap for ZnO

Researches prove that the energy of a material band gap is significantly affected by the radiation of pulsed laser beam energy however when low incident laser energy hits the target, the size of the ablated ZnO NPs is large with lower nanoparticle concentration, the estimated band gap in ethanol solution is 3.3 eV at 500 mJ of laser energy. However high laser energy increases the laser radiation intensity delivered to the target and thus increases the amount of the NPs with smaller size and hence the band gaps as shown in Fig. (6a). at 700 mJ the band gap of ablated nano particles is 3.55 eV now unexpected decreasing in band gap at laser energy of 900 mJ this because of the high density of nano particles ablated which cover the surface of the target absorbing the energy of the incident laser beam and effately reduces the band gap of the generated nano particles to 3.5 eV, by the way this behavior is strongly appears in Fig.(6b). Table (2) illustrates the laser energies and their band gaps. Fig.(6a,b) and Table (3) shows the variation of laser band gaps with respect to changing the number of laser pulses at different samples prepared LPLA technique. This figure shows the increase in the number of the laser pulses lead to increase the band gaps where at 60 pulse it record 3.5eV while at 100 pulse the band gap is 3.54 eV however at higher measured pulse of 140 pulse 3.66 eV this tells us the formation of smaller nano particle size which raise to

quantum confinement effect. It also found that all samples give higher band gap energy then the bulk ZnO (3.2 eV) [9].

The reason for decreasing the size of the nano particles which gives higher energy band gap is because the increase in the number of laser pulses lead to increase the quantity of NPs in the suspension, these nano particles will intercept the laser beam incident on the target when they gathered near the surface of the ethanol. This will causes fragmentation of the first NPs produced and cause to the reduction of size of the nano particles produced at higher laser pulses.

Table (2)

Shows the variation of laser band gaps with respect to laser energies.

Solvent	No. of pluses	Laser energy (mJ)	E _g (eV)
Ethanol	100	500	3.3
		700	3.55
		900	3.5

Table (3)

Variation of laser band gaps with laser pulses.

Solvent	No. of pluses	Laser energy (mJ)	E _g (eV)
Ethanol	60	700	3.5
	100		3.54
	140		3.66

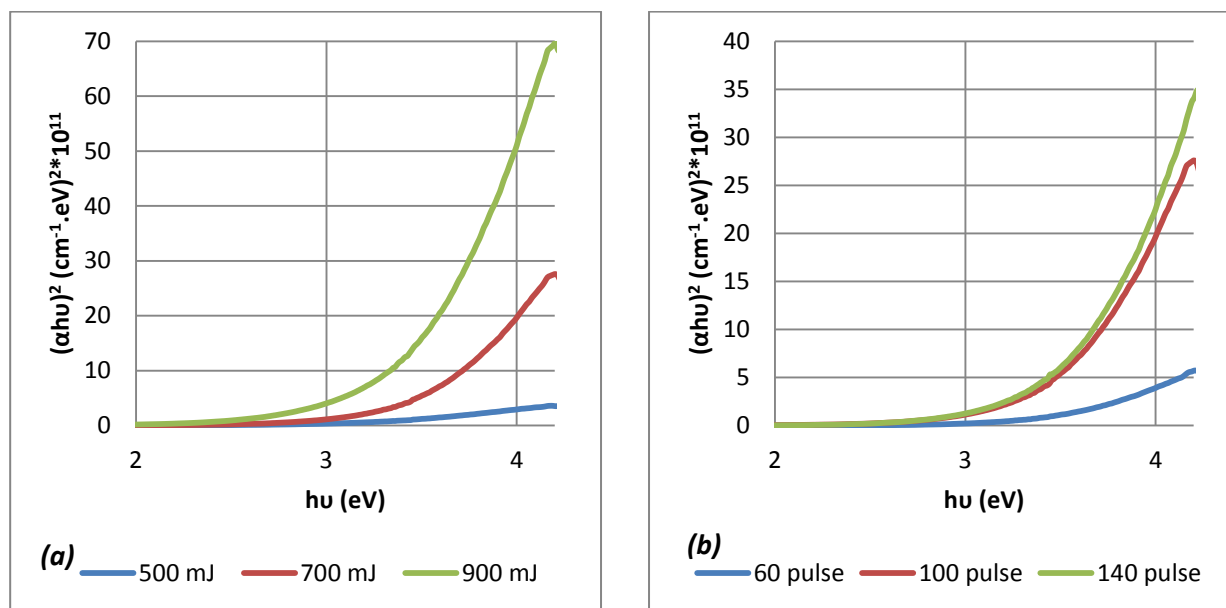

Fig.(6): Shows the energy band gap of the UV-Vis measurement for different (a) Laser energies and (b) Number of laser pulses.

3.4 Transmission Electron Microscopes (TEM)

Fig.(7) illustrate the TEM images of ZnO NPs processed by LPLA technique by immersing a Zn pellet in the bottom of the vessel or container of volume 3 ml of ethanol solution. This process is done by focusing the pulse laser beam of 1064 nm for Nd:YAG laser with laser energy of 500 mJ and repetition rate of 1Hz and 10 ns pulse duration, the focal length of the laser lens is 8.25 cm. the distance between the target surface and the ethanol surface was 2mm. the number of laser pulses were 100 pulse. The properties of nanoparticles suspension such as particle aggregation and size were identified by using TEM type CM10 PW 6020, Philips-Germany. The images were obtained at an accelerating voltage of 40-90 kV, with maximum magnification of 45000 \times -1500000 \times . This process done in order to conform following studies:

1. The calculation of the average particles sizes of NPs prepared by LPLA technique which perform a successful quantum confinement of an average of 60 nm this measurement agreed with the XRD measurement in nano particle size.
2. It proves the formation of the aggregation behavior due to a small electrostatic attractive force between the nano particles

by weak bonds that called van der Waals forces or by other ionic covalent bonds.

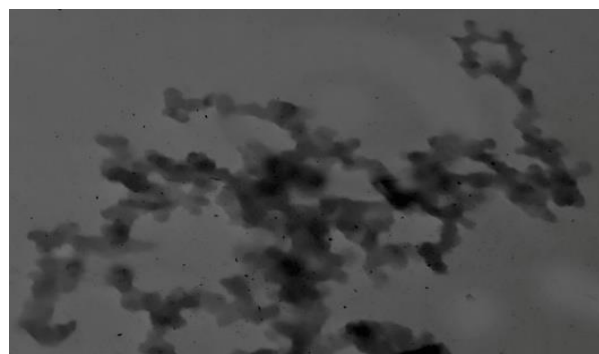

Fig.(7): Shows the TEM morphology of prepared nano particles of ZnO nano particles formed by ablation of Zn target immersed in ethanol of laser energy of 500 mJ and laser pulse of 100 pulses.

3.5 Conclusions

Liquid phase laser ablation (LPLA) technique is a very simple, easy, useful and controllable technique to prepare NPS for versus application, the results have been studied for different parameters and the results illustrate that increasing the laser energy and number of laser pulses, the energy band gap of the ablated NPS increased as well.

References

- [1] Song Z., Kelf T. A., Sanchez W. H., Roberts M. S., Ricka J., Frenz M. and Zvyagin A. V. "Characterization of optical properties of ZnO nanoparticles for quantitative imaging of transdermal transport" *J Biomed Opt Express*, 2(12), 3321–3333, 2011.
- [2] Kumar S. S., Venkateswarlu P., Rao V. R. and Rao G. N. "Synthesis, characterization and optical properties of zinc oxide nanoparticles" *J International Nano Letters*, [6p.], 2013.
- [3] Ghosh S. P. "Synthesis and characterization of zinc oxide nanoparticles by sol-gel process" [master's thesis]. India: National Institute of Technology, Rourkela; 36 P, 2012.
- [4] Savchuka A. I., Perroneb A., Lorusso A., Stolyarchuk I. D., Savchuk O. A. and Shporta O. A. "ZnMnO diluted magnetic semiconductor nanoparticles: Synthesis by laser ablation in liquids, optical and magneto-optical properties" *J Applied Surface Science*, 302,1-4, 2013.
- [5] Radzimska A. K., Jesionowski T. "Zinc Oxide-From Synthesis to Application: A Review" *J Materials*, 7, 2833-2881, 2014.
- [6] Costovici S., Petica A., Dumitru C., Anca C. and Liana A. "Electrochemical Synthesis of ZnO Nanopowder Involving Choline Chloride Based Ionic Liquids" 41, 343-348, 2014.
- [7] Mirghassemzadeh N., Ghamkhari M., Dorrani D. "Dependence of Laser Ablation Produced Gold Nanoparticles Characteristics on the Fluence of Laser Pulse" *Soft Nanoscience Letters*, 3, 101-106, 2013.
- [8] Desarkar H. S., Kumbhakar P., Mitra A. K. "Effect of Ablation Time and Laser Fluence on the Optical Properties of Copper Nano Colloids Prepared by Laser Ablation Technique" *J Applied Nanoscience*, 2(3), 285-291, 2012.
- [9] Semaltianos N. G., Logothetidis S., Perrie W., Romani S., Potter R. J., Sharp M., French P., Dearden G. and Watkins K. G. "CdSe nanoparticles synthesized by laser ablation" *A letter journal exploding the frontiers of physics*, 84, [6 p.], 2008.